

Lead screw

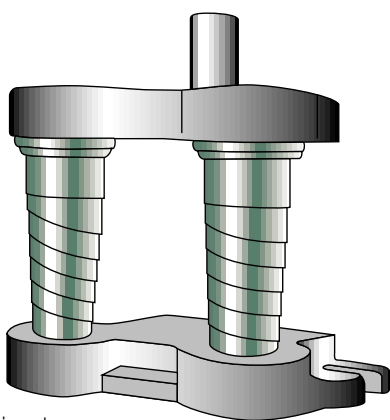

Die sets

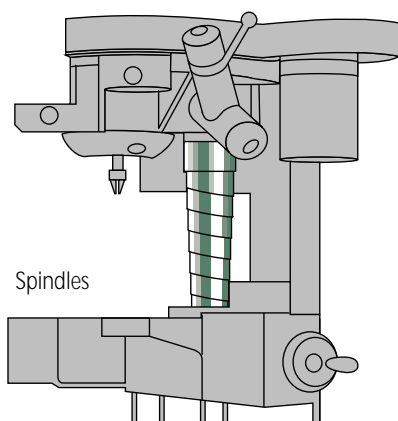

Spindles

### Lead Screw Guards

There are limitless applications for Spiroflex's "Lead Screw Covers". Featured is the most widely used of all, machine tools, and how the Lead Screw Cover can be used to protect and preserve the most valuable of moving parts. Providing protection to an operator from hazards, the Lead Screw Cover can be used to cover many moving parts.

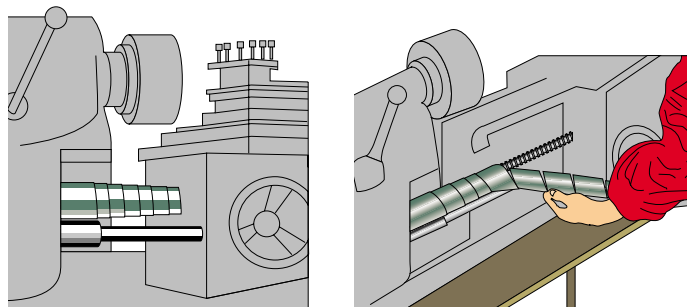

There is no need to dismantle machines; Lead Screw Covers can be wound on for instant use.

Once fitted the guard protects permanently without the need for lubrication.

## When sending an enquiry please specify the following details:

- A = The inside diameter to clear the column/shaft
- E = The maximum extended length (indicating if the application is vertical or horizontal)
- B = The maximum diameter over the guard (if there are limitations)
- W = The minimum extended length (if there are limitations)  
= Boss size internal and external

N.B. Locating bushes not supplied with guards.

If you require further assistance, please call our technical sales dept for advice.

## Standard Size Range

PART NUMBER	A I/D	B O/D	E EXTENSION	W WIDTH
N6028	25.4	39.4	571	50
N6329	28.956	45.466	546.1	38.1
N6236	30.5	43.4	533	50
N6237	30.5	51.6	787	50
N6716	31	56	648	40
N6027	31.8	50.3	406	38
N6017	31.8	43.4	457	50
N6459	33	56.4	1333	76
N6203	35	51	690	50
N6002	38	52	483	50
N6726	38.1	60.325	304.8	31.75
N6721	38.1	60.325	711.2	50.8
N6129	38.1	54.9	381	38
N6468	38.1	49.3	381	50
N6431	41	67.3	1016	63
N6025	44.45	59.69	457.2	50.8
N6719	44.45	79.375	1524	101.6
N6007	44.5	63.5	610	50
N6110	50.2	76	1350	100
N6707	51	65	250	50
N6513	51	80	1193	75
N6364	51	89	1829	100
N6069	54	71.4	305	38
N6394	60	95	1150	145
N6139	69.8	83.6	229	50
N6410	76	100	1219	100
N6351	76	115	1321	100

